

## *Instructions for Activating an External Music On Hold (MOH) Device – AT&T Syn248 with a SB35025 Deskset Only*

**AT&T SB35020/SB35025 Deskset** — These Deskset models feature a standard screen and programmable feature keys. The SB35025 has a DECT 6.0 radio with an audio in/out port for connecting a Music on Hold (MoH) source.

If an SB35025 Deskset is installed, connect an optional Music on Hold source. Use the supplied audio in/out cable. Its L-shaped connector is designed to fit into the space available behind the Deskset.

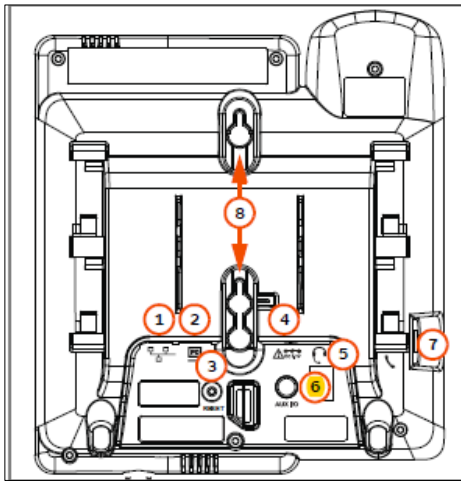

< View of the bottom of the SB35025

#6. AUX I/O Port: SB35025 Deskset only — For connecting a Music on Hold source and/or a single-zone overhead paging system.

### **Connecting Your Messenger USB Music on Hold Source**

Note: The volume on the Messenger USB Music on Hold Source should be used to obtain the preferred level of music on hold for your callers.

When connecting an MoH source, ensure that you use the supplied audio in/out cable to connect the source to the SB35025 Deskset AUX I/O port.

### **To install a music on hold source:**

1. Connect an audio cable with 1/8-inch (3.5 mm) jacks from your Messenger USB Music on Hold Source to the “Music on Hold Input” jack of the audio in/out cable supplied with the SB35025 Deskset. See Figure 15.

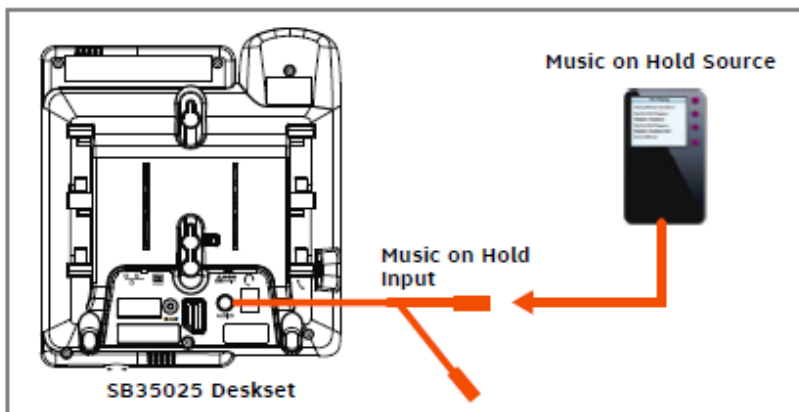

**Figure 15. Music on Hold Source Installation**

2. Connect the supplied audio in/out cable to the SB35025 Deskset **AUX I/O** port.
3. Log on to the WebUI to configure the Music on Hold settings. The Music on Hold settings are listed under **Hold Settings** in the WebUI. You must: Enable Music on Hold. Select the extension (Deskset) to which you have connected the music on hold source.

### Configuring Hold Settings

In the navigation menu at left, click Hold Settings. The Hold Settings page appears

**Hold Settings**

---

**Hold Music**

Music on Hold:  Enable  Disable

Select Port: Ext. 200

---

**Hold Announcement**

Hold Announcement:  Enable  Disable

Delay Before Playing: 0 seconds

Delay Before Repeating: 15 seconds

Hold Announcement Recording:

- Under Hold Music, if you have a Music on Hold source connected, click Enable.
- Select the Port, which is the extension number of the SB35025 Deskset to which the Messenger USB Music on Hold Source is connected. All SB35025 Desksets installed in the Syn248 system appear in the list.
- Select “Apply” to save changes.

If you have any questions or issues, please contact us at 866-359-4653 or [info@telephoneonhold.com](mailto:info@telephoneonhold.com).



Telephone On Hold  
866-359-4653  
[www.telephoneonhold.com](http://www.telephoneonhold.com)